

AFA Systems

Packaging Automation

CE-CEB Automatic Case Erector and Bottom Sealer



CE-CEB Case Erectors are an excellent addition to your production line. The CE-CEB will automatically erect a case and then seal the case bottom. You have the option of either hot melt glue or tape closure. In addition, the compact design of the CE-CEB can allow for flexibility when integrating the system into your production line to meet customer requests. Furthermore, the CE-CEB will erect difficult corrugated cases with ease and with minimal rejections. Stainless steel construction provides longevity and a clean look. Easily maintainable and fast and accurate changeover are standard on the CE-CEB. Add value to your production line with the CE-CEB.

Features

- » Magazine capacity of approximately 150 cases
- » Small footprint
- » Speeds up to 12 cases per minute
- » Maintenance free drive assembly
- » AFA tape head
- » NEMA 12 electrical panel
- » Air consumption: 80 PSI
- » Mitsubishi Inverter
- » Can be used as either a stand-alone unit or can be easily integrated into your production line



www.afasystemsinc.com

Typical Floor Plan

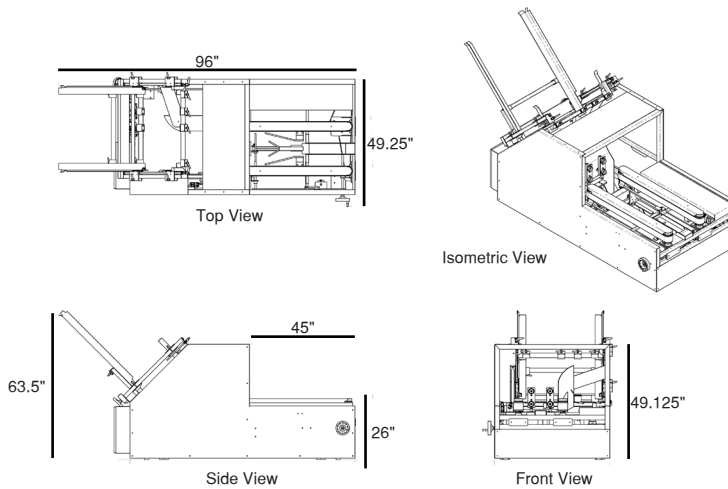

Key Components

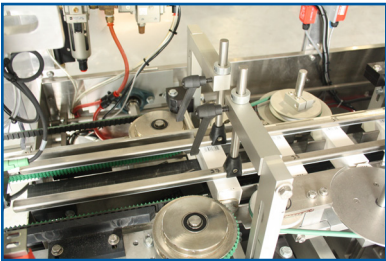

The CE-CEB offers a simple changeover process. The operator will release the ratchet handles and adjust the rails and guides to fit with your case size.



A case sensor on your magazine is an excellent way to track supplies and notify operators when the case magazine is running low on cases.



Discharge belts at the end of the CE-CEB reduces carton marking when transferring a case onto another system. Discharge belts are also an excellent way to reduce case jamming.

Case Size Range

Standard	L	W	D	
Size Ranges (Inches)	min.	8	6	6
	max.	20	20	16

* If size outside case size range please check with AFA Representative

